

Proportional Pressure Reducing Valve

(Sizes 1½-20"; DN40-500)

Description

The Model 720-PD Proportional Pressure Reducing Valve is a hydraulically operated, diaphragm actuated control valve that reduces higher upstream pressure to lower downstream pressure at a fixed ratio, regardless of fluctuating demand or varying upstream pressure.

Installation

1. Ensure enough space around the valve assembly for future maintenance and adjustments.
2. Prior to valve installation, flush the pipeline to insure flow of clean fluid through the valve
3. For future maintenance, install Isolation gate valves upstream and downstream from Bermad control valve.
4. Install the valve in the pipeline with the valve flow direction arrow in the actual flow direction. Use the lifting ring provided on the main valve cover for installing the valve.
5. For best performance, it is recommended to install the valve horizontally and upright. For different valve positions – consult Bermad.
6. After installation carefully inspect/correct any damaged accessories, piping, tubing, or fittings.
7. Install a pressure gauge (instead of the plastic plug on the pilot)
8. It is highly recommended to install a strainer Bermad model 70F upstream from the pressure reducing valve, to prevent debris from damaging valve operation.

Commissioning & Calibration

1. Confirm that cock valve [2], is open (handle parallel to cock-valve body).
2. Open fully the upstream isolating valve and partially the downstream isolating valve, to fill-up, in a slow and controlled manner, the consumers line downstream from the pressure reducing system.
3. Confirm that the supply pressure and the flow through the system are typical. If necessary, create flow by opening a hydrant, or reduce the flow/pressure by adjusting the downstream/upstream isolating valves.
4. Vent air from the valve's control loop by loosening cover tube fitting at the highest point, allowing all air to bleed. Retighten the tube fitting eyebolt.
5. The Model 720-PD reduces the upstream pressure in a fixed ratio of 1:2.2 to 1:4, according to the valve diameter & plug (see table below). Allow the pressure that appears in the downstream pressure gauge (installed between the valve and the downstream isolating valve or the second stage control valve) to stabilize, meeting the desired value.

Note: the reduction ratio is average; it might be slightly higher at very high flow rates.

6. After the pressure is stabilized, open fully the downstream isolating valve.
7. Relief Valves should be set 1 bar above system highest possible pressure (max. upstream pressure divided by valve reduction ratio).
8. Reduction Ratio Table:

700 & 700-EN			700-ES		
Valve Size	Flat Disc	V-Port	Valve Size	Flat Disc	V-Port
DN50-DN65; 1½"-2½"	3.7	4.0	DN50-DN65; 1½"-2½"	2.8	3.2
DN80; 3"	2.6	2.9	DN80; 3"		
DN100; 4"	2.5	2.8	DN100; 4"	2.6	2.9
DN150; 6"	2.5	2.7	DN150; 6"	2.5	2.8
DN200; 8"	2.4	2.6	DN200; 8"	2.5	2.7
DN250; 10"	2.3	2.5	DN250; 10"	2.4	2.6
DN300-DN350; 12"-14"	2.2	2.4	DN300; 12"	2.3	2.5
DN400-DN500; 16"-20"	2.0	2.2			

Control Drawing

PARTS LIST
2 2W Cock Valve

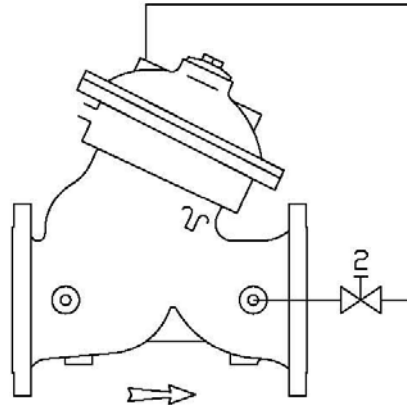

Trouble-Shooting

1. **Valve fails to Open:** Check for sufficient inlet pressure, create demand/flow, check cock valves status.
2. **Valve fails to Close:** Valve closes only @ No-Demand/flow. Check cock valves status, detect for clogged ports or fittings, check if any debris trapped in the main valve, confirm diaphragm is not leaking.
3. **Valve fails to Regulate:** Release air trapped in the control chamber & check cock valves status.

Preventative Maintenance

1. System operating conditions that effect on the valve should be checked periodically to determent the required preventative maintenance schedule.
2. Maintenance instructions:
 - 2.1. Tools required:
 - 2.1.1. Metric and imperial wrenches
 - 2.1.2. Anti seize grease
 - 2.2. Visual inspection to locate leaks and external damages
 - 2.3. Regulation functional inspection.
 - 2.4. Close upstream and downstream isolating valves (and external operating pressure when used).
 - 2.5. Once the valve is fully isolated vent pressure by loosening a plug or a fitting.
 - 2.6. Open the stud nuts and remove the actuator as one unit from the valve body. Disassemble necessary control tubs.
 - 2.7. It is highly recommended to stock a reserve actuator assembly for each size. This allows minimum system field work and system down time.
 - 2.8. Disassemble the actuator and examine its parts carefully for signs of wear, corrosion, or any other abnormal conditions.
 - 2.9. Replace worn parts and all the Elastomers. Lubricate the bolts and studs threads with Anti seize grease.

Spare parts

Bermad has a convenient and easy to use ordering guide for valve spare-parts and control system components. For solenoid valves refer to model and S/N on solenoid tags.

Pub # : IOMEW720-PD	By: YE 1/08	Rev: 02YE-1/09	File name: IOMEW720-PD_01_09
---------------------	-------------	----------------	------------------------------

appliceng@bermad.com • www.bermad.com

The information contained in this document is subject to change without notice.

BERMAD shall not be liable for any errors contained herein. All Rights Reserved. © Copyright by BERMAD Control Valves.